

PGE-50-26

Slim-type Electric Parallel Gripper

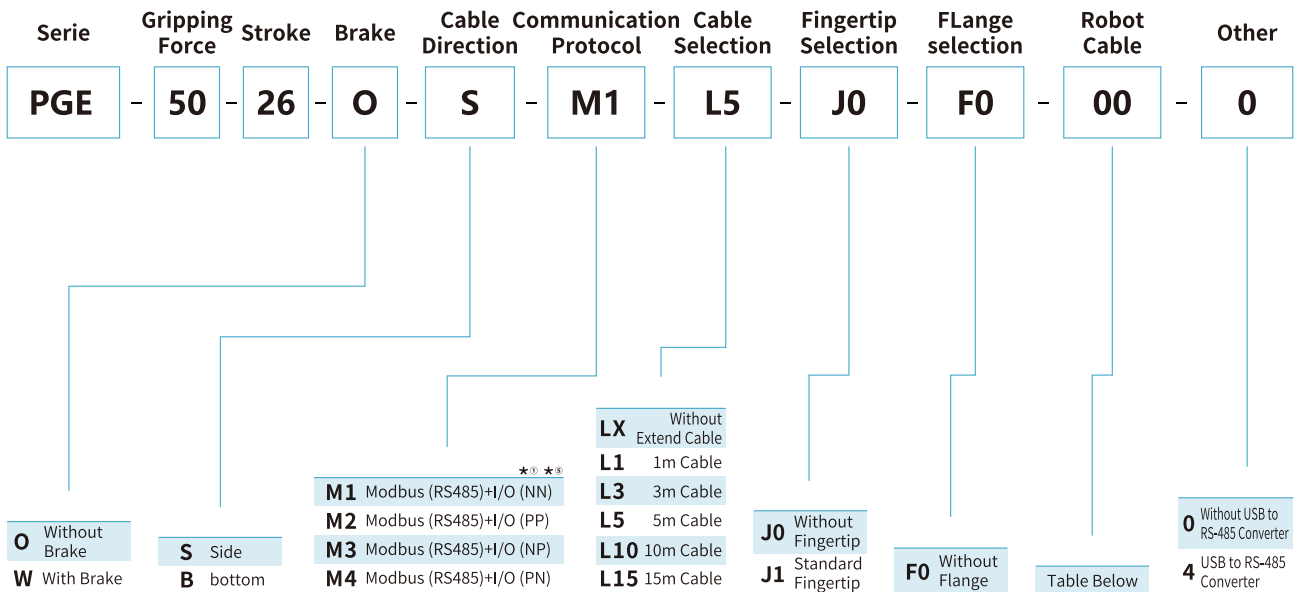

Selection Method



*① Note:

I/O(NN): NPN/NPN
I/O(PP): PNP/PNP
I/O(NP): NPN/PNP
I/O(PN): PNP/NPN

00 Without Robot Cable	01 Elite CS UR CB	SIASUN Hanwha A UR E	DOBOT CR DOBOT Nova	02 AUBO 03 ELEPHANT	04 JAKA 05 TECHMAN	06 ROKAE SR ROKAE ER 07 DOBOT MG400	09 Doosan A 10 Doosan M	11 Elite EC 12 Han's	13 Neuromeka 14 FAIRINO	15 Hanwha HCR 16 UF x Arm 17 ROKAE CR
-------------------------------	-----------------------------	----------------------------	------------------------	--------------------------------------	-------------------------------------	--	--	---------------------------------------	--	--

*⑤ It is recommended that no more than 4units of DH-Robotics products be accessed on a single 485 bus, otherwise 485 communication anomalies may occur. If you need to access more than 4 devices, it is recommended to contact the sales staff for product adjustment.

