

# PGE-15-26

Slim-type Electric Parallel Gripper

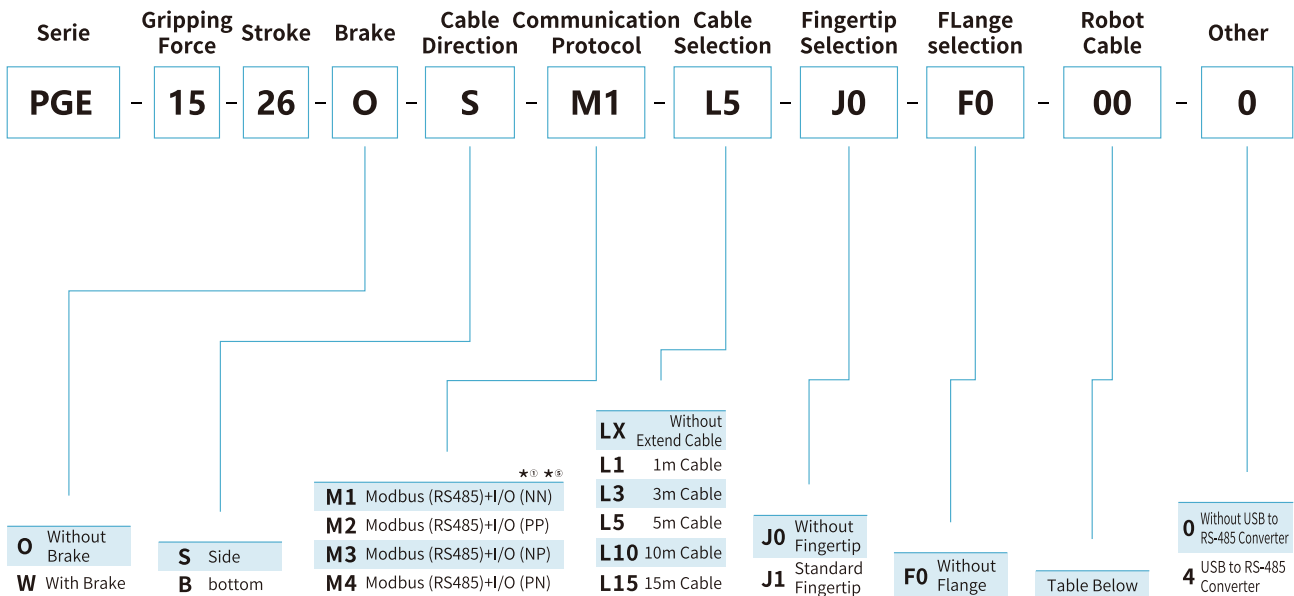

## Selection Method



\*① Note:

I/O(NN): NPN/NPN  
 I/O(PP): PNP/PNP  
 I/O(NP): NPN/PNP  
 I/O(PN): PNP/NPN

<b>00</b> Without Robot Cable	<b>01</b> SIASUN Elite CS UR CB	<b>02</b> DOBOT CR DOBOT Nova	<b>03</b> ELEPHANT	<b>04</b> JAKA	<b>05</b> TECHMAN	<b>06</b> ROKAE SR ROKAE ER	<b>07</b> DOBOT MG400	<b>09</b> Doosan A	<b>10</b> Doosan M	<b>11</b> Elite EC	<b>12</b> Han's	<b>13</b> Neuromeka	<b>14</b> FAIRINO	<b>15</b> Hanwha HCR	<b>16</b> UF x Arm	<b>17</b> ROKAE CR
-------------------------------	---------------------------------	-------------------------------	--------------------	----------------	-------------------	-----------------------------	-----------------------	--------------------	--------------------	--------------------	-----------------	---------------------	-------------------	----------------------	--------------------	--------------------

\*⑤ It is recommended that no more than 4units of DH-Robotics products be accessed on a single 485 bus, otherwise 485 communication anomalies may occur. If you need to access more than 4 devices, it is recommended to contact the sales staff for product adjustment.

